



Shutt Limited Warranty

Shutt Auto Accessories, warrants to the original purchaser at retail that this product will be free from defects in material and workmanship under normal and ordinary use for a period of one year from the date of original purchase. This warranty is automatically void if the product is sold, assigned or transferred to anyone other than the original purchaser of the product.

The following exclusions and limitations apply to all Products under all warranties offered by SHUTT:

- This warranty is void if, in SHUTT's opinion, damage to the Product is due to abuse, improper installation, misuse, blunt force or trauma to the Product, modification of the Product, or negligence.
- This warranty does not cover any leather damage or discoloration of the Product caused by hand sweat, solvents or similar fluids or products (i.e. waxes or silicone formulas).
- This warranty does not cover scratches on surfaces caused by sharp and abrasive objects (i.e. rings, bolts and screws).
- SHUTT reserves the right to request proof of original ownership and related documentation and/or to inspect the damaged Product at SHUTT's laboratories prior to the issuance of any replacement Product.
- This Limited Warranty terms may also vary from state to state and country to country.

171500151 - 2009/02

Purchase Date::



Store:

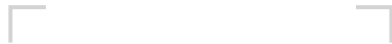

Stamp



Uneni Ind. Com. Imp. Exp. Ltda. - C.N.P.J. 74.522.251/0001-72

www.Shutt.com.br



Orbitt G-II Shift Knob Phantom G-II Shift Knob

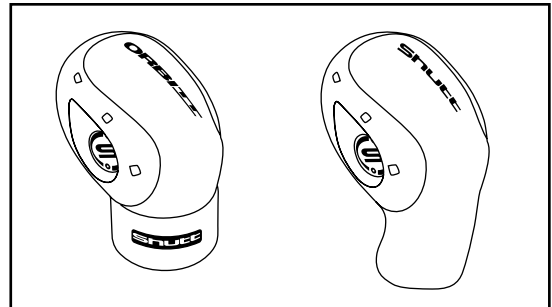

Instructions Manual



Orbitt G-II Shift Knob

Assembly Project:

- 1) After removing the original shift knob from the shifter, insert one of the filler tubes all the way in the shifter. (try each one to find which stays firmer).
- 2) Twist the bottom ring to separate-it from the shift knob, and place it in the shifter with the tread side up
- 3) With the provided Allen screw driver, loose the 3 screws concealed in the shift knob tread and insert it all the way in the shifter over the plastic filler tube.
- 4) Tighten all 3 concealed screws equally, adjusting each to get the best alignment.
- 5) Screw back up the bottom ring into the shift knob

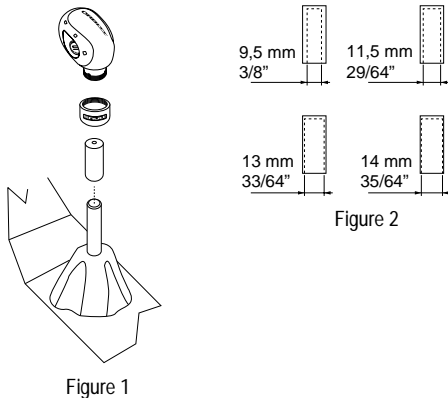

Phantom G-II Shift Knob

Assembly Project:

- 1) After removing the original shift knob from the shifter, insert one of the filler tubes all the way in the shifter, (try each one to find which stays firmer).
- 2) With the provided Allen screw driver, loose screw concealed in the leather between the threads close to the bottom.
- 3) Insert it all the way in the shifter over the plastic filler tube.
- 4) Tighten the concealed screw until knob is firm.

